

# Húsavík Energy

## Multiple use of geothermal energy

Thermie project nr. GE 321 / 98 / IS / DK  
Hreinn Hjartarson, Húsavík Energy  
Runólfur Maack, VGK  
Sigþór Jóhannesson, Fjarhitun

Email: hreinn@husavik.is, runolfur@vgk.is, sigthor@fjarhitun.is

### Abstract

Húsavík town is located on the coast of Skjálfandaflói in the northern part of Iceland. Twenty 20 km south of Húsavík is the Hveravellir geothermal area. Geothermal fluid from three boreholes that were drilled there in 1974 – 1998 ranges in temperature from 115° to 130°C. Close by are several natural hot springs and pools that discharge about 100°C hot water.

Húsavík Energy started utilisation of geothermal hot water from Hveravellir as early as 1970. Until the year 2000 the Hveravellir fluid was flashed to 100°C at the wellhead and the hot water fed under gravity to the town through a 20 km long buried asbestos cement pipeline. There it was used for space heating, drying and also to heat greenhouses and farmhouses in the district. Temperature drop along the route was up to 15°C and significant thermal energy was also lost in the flashing process.

In the nineties it became clear that the old pipeline needed a thorough overhaul. In Húsavík new markets for 80°C to 120°C hot water were being developed both for heating and industrial use. This prompted the idea of expanding the foreseen refurbishment of the existing system to include diverse cascaded uses. In connection with renewal of the pipeline it was decided to change operation of the whole system. The main goals were:

- to secure energy supply to the consumers in the future.
- to increase diverse use of geothermal energy.
- to utilise the geothermal energy and large quantity of cold fresh water to attract new industrial utilities into the area and strengthen economy in general.
- to extract more energy from the geothermal fluid.

To achieve these goals 124°C geothermal fluid from the production wells is in the new system transported under pressure to the Energy Centre located in the town. The Energy Centre building houses Kalina Binary Electric Power Plant, heat exchangers and control equipment. The net output of the electrical plant is 1.7 MW, which suffices to meet about three-quarters of the town's current electricity demand. In the electric power plant the water is utilised down to 80°C which is proper water temperature for the district heating system and various other applications.

From the Energy Centre water of resp. 120°C and 80°C in temperature is piped to the diverse industrial users in Húsavík and to the town's district heating system.

Furthermore, the geothermal water is used for fish farming, greenhouses, health centres and bathing facilities.

Such an integrated system renders vastly improved efficiency in the utilisation of the geothermal energy.

The paper describes reconstruction of the geothermal system in Húsavík, the process design and the system facilities.

**Keywords:** geothermal, multiple use, effective use, efficiency, flexibility, sustainability

# 1 Introduction

Húsavík is the largest town in Northeast Iceland with a population of around 2,500 inhabitants. Húsavík has been an active trading post since 1614 and the town's economy has since that time mainly been based on fishing, fish processing and service for the surrounding countryside. However, tourism and other industries have played an increasing role during recent years. The main natural resources of the Húsavík area are plentiful fishing waters, geothermal heat and an abundant supply of fresh, cold water.

In 1969 Fjarhitun hf. Consulting Engineers carried out a feasibility study for a geothermal district heating system in Húsavík. The outcome of the study was that the most economical way to construct such a district heating system was to utilize hot water from springs at Hveravellir, 20 km south of Húsavík. The chemical composition of the water at Hveravellir allows direct use, unlike the water from the wells that had been drilled in Húsavík the previous years. The construction of a pipeline from Hveravellir to Húsavík began in the spring of 1970. At the end of that same year all houses in Húsavík had been connected to the geothermal district heating system.

Initially the district heating system used 100°C hot water directly from the springs, but in 1974 a 450 m deep well, H1, was drilled. Well H1's production was approx. 40 l/s of 128°C hot water, in addition to the 43 l/s that the springs produced. The utilization of the 83 l/s available was divided between the greenhouses in Hveravellir which received 9 l/s and Húsavík which received 74 l/s, used for the town's swimming pool and its district heating system.

Despite the temperature of the water from H1 being at 128°C, utilization was limited to water at a lower temperature or 100°C. Approximately 2.2 kg/s of steam was lost to the environment when the geothermal fluid was separated at atmospheric pressure. As stands to reason a lot of energy was lost during this process. Losses were also incurred on the way from Hveravellir to Húsavík, the water traveling the 18 km distance through an un-insulated, subsurface, asbestos-reinforced cement pipe. On the way the water lost 15°C, arriving in Húsavík at a temperature of 85°C. The altitude difference between Húsavík and Hveravellir is around 100 m, Húsavík being the lower area, so no pumping was needed.

Demand continued to increase so a new borehole, H10, was drilled at Hveravellir in 1998. Well H10 turned out to be quite productive, today providing approx. 60 l/s of 124°C water at 2 bar (0.2 MPa) pressure.

Preparations for the renewal of the asbestos-reinforced cement pipe between Hveravellir and Húsavík began in 1998. Since the geothermal water at Hveravellir is hot enough for both industrial use and district heating needs, the idea to aim simultaneously for multiple or cascade use of the resource developed. A complete revision of the system was decided upon, to be based on the following objectives:

- Ensure sufficient energy at all times for all customers of Húsavík Energy.
- Ensure an appropriate temperature of water for each customer's need.
- Increase efficiency in utilization of the geothermal energy.
- Improve the variety of geothermal energy use.
- Use the geothermal energy, as well as the abundant supply of fresh cold water to attract new customers and strengthen the industrial society in the area of Húsavík.

Orkuveita Húsavíkur (Húsavík Energy) applied for a grant from the fourth framework program of the European Union. The application was based on the project's demonstrative characteristics regarding innovative multiple use of geothermal energy. The project was granted 663,000 € (around 56,000,000 ISK, based on the exchange rate in early May 2002).

The project was completed in 2001 and a final report sent to the European Union, which has accepted the report without comment.

This report highlights the project's major elements as well as its progress.

## 2 The geothermal field

The geothermal energy at Hveravellir has long been utilized in neighbouring greenhouses and farms. Since Húsavík Energy began operating in 1970, withdrawal from the field has been monitored. An average 80-85 l/s of 100°-128°C hot water has been withdrawn from the field.

The National Energy Authority of Iceland published a report regarding the potential magnitude of the geothermal resource at Hveravellir in January 1998 [4]. The report states that the Hveravellir geothermal field is able to withstand withdrawal from boreholes amounting to at least 190 l/s of hot water.

Wells H17 and H18 were drilled in 1998 and provide a very poor flow of water, despite temperature readings of close to 130°C. Well H16 merely provides about 8 l/s of 115°C hot water. The National Energy Authority has stated that its estimate of the geothermal field's potential is not in need of review, it is merely the matter of finding the correct drilling sites.

Figure 2.1 depicts the general plan of the geothermal field at Hveravellir. Included are the location of drilled wells (denoted with H) and hot springs in the area. For clarification, the names of all springs end with “hver”.

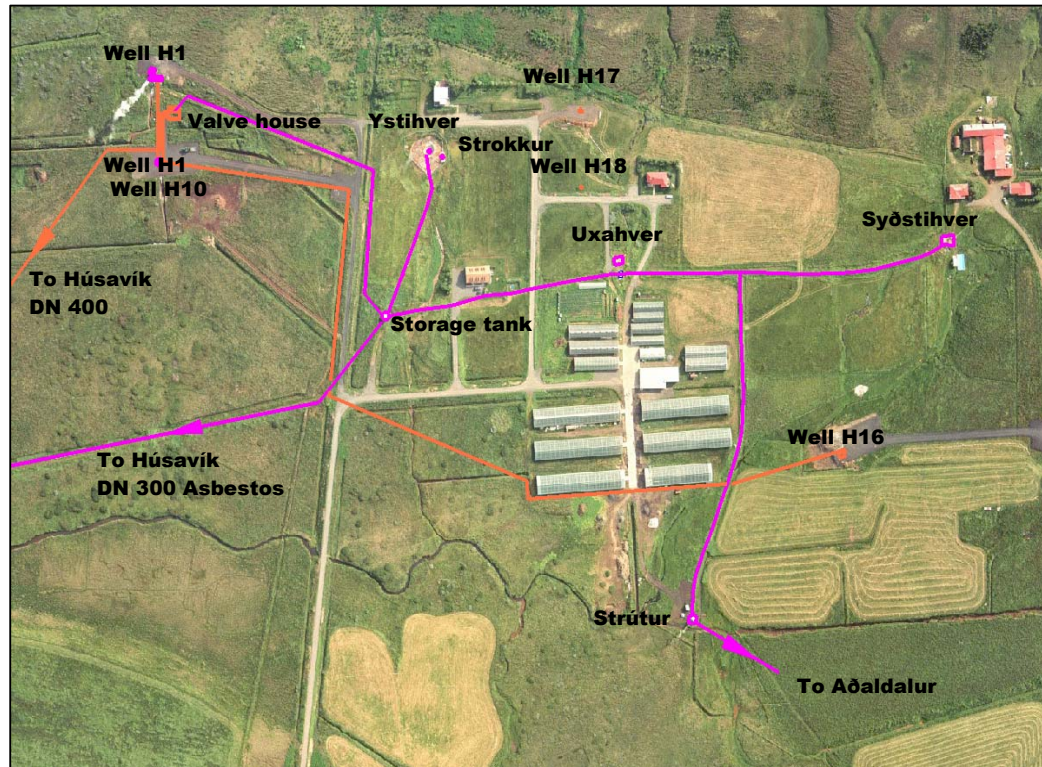

Fig 2.1. The geothermal field at Hveravellir

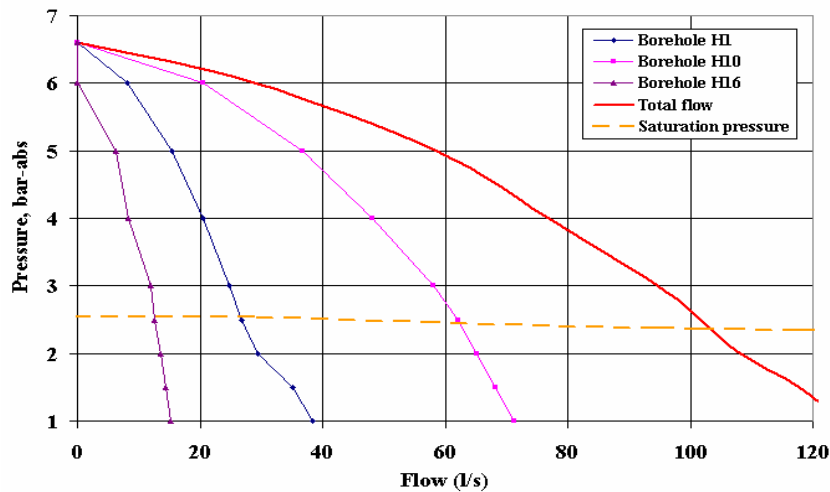

Figure 2.2 shows flow and pressure measurements from wells H1, H10 and H16. As is to be expected, flow from the wells decreases when well-head pressure is increased. A pressure of 6.6 bar<sub>a</sub> is required to close wells H1 and H10 but 6 bar<sub>a</sub> to close well H16.

Fig 2.2. Hveravellir – Well performance.

A decision to defer further drilling was made and thus to commence operation of the new district heating system using only the water available from wells H1, H10 and H16. Table 2.1 lists the performance of wells H1, H10 and H16 at 2.5 bar<sub>a</sub> pressure into the supply main.

Table 2.1 Performance of wells H1, H10 and H16

Wells	Flow, l/s	Temperature, °C
Well H1	26	128
Well H10	61	124
Well H16	8	115
Wells H1 and H10	87	125
Wells H1, H10 and H16	95	124

## 3 Geothermal system

### 3.1 Changes in the geothermal system

As stated in the introduction, the district heating system of Húsavík initially utilized 100°C surface flow from hot springs at Hveravellir. After well H1 had been drilled, additional water at 128°C was provided into the system. Since water from the well is at 128°C it had to be cooled down to 100°C by boiling at atmospheric pressure before entering the system. In the cooling process 2,2 kg/s of steam was released into the atmosphere. The total supply from well H1 and hot springs was 83 l/s, all of which was covered by the local demand. The 100 m difference in height between Húsavík and Hveravellir, Húsavík being the lower spot, enables pure gravity flow of the medium all the way to Húsavík. Pumping in the district heating system was only required for the highest standing houses in Húsavík in addition to having to pump the hot water to the municipality of Aðaldalur. An estimated 70-80% of all flow to consumers required no pumping. Thus the operational safety of the district heating system was high, the system was easily maintained and inexpensive to operate – resulting in one of the lowest energy prices in Iceland.

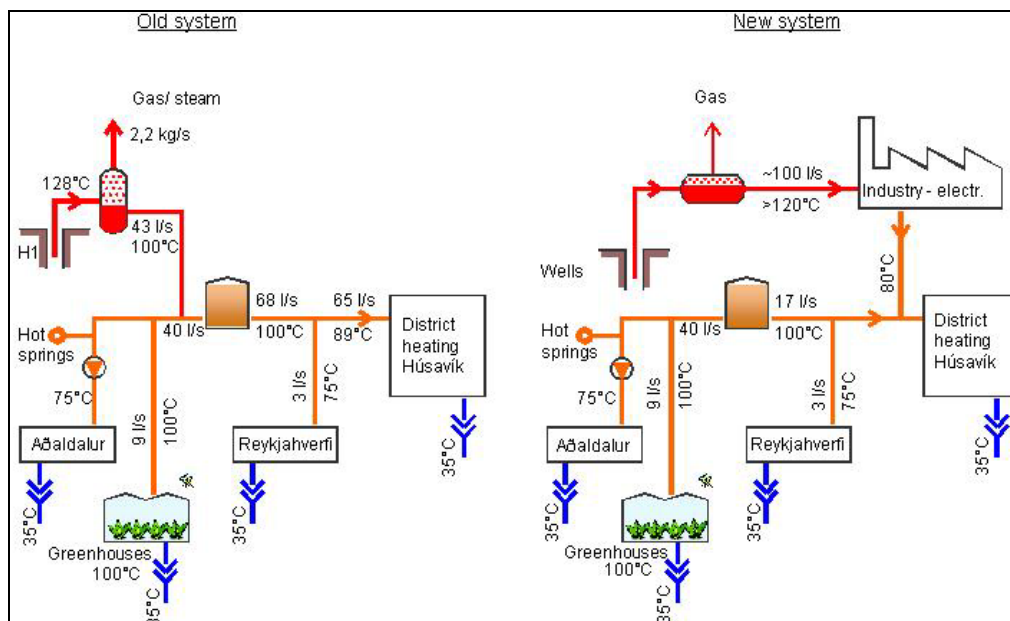

Figure 3.1.1. Changes in utilization of geothermal heat

When the time came to renew the main supply pipe from Hveravellir to Húsavík and increase production, a strategic decision was called for. Should the operating conditions that had worked well for three decades be left unchanged - or should a different setup with other goals, such as those stated in the introduction, be considered? The decision reached was to make changes necessary for full utilization of the heat available from the 124-128°C water. **Figure 3.1.1** shows the main changes in the utilization of geothermal heat from Hveravellir that followed.

The major change in the process is that the water now enters the supply pipeline to Húsavík directly, without prior cooling from 124-128°C down to 100°C. This modification makes it possible to produce electricity or utilize the water for a variety of industrial purposes, before it enters the district heating distribution network in Húsavík.

### 3.2 New geothermal system

**Figure 3.2.1** shows the system diagram of the new district heating system. Included are the main components of the system and the utilization possibilities.

The system is very flexible. It allows for increased flow of 120°C water to industry, accomplished by decreasing electricity production. The flow of 80°C water to industry can also be increased when the demand for district heating in Húsavík decreases. In addition, flow to the bathing lagoon and to fish-farming can be controlled upon demand. Flow related values in **fig. 3.2.1** indicate flow in the system at periods of maximum demand for district heating and electricity production in 2001.

Surface flow from the hot springs at Hveravellir supply the system with 34 l/s of 100°C water. This water is utilized in the same manner as before: in greenhouses in Hveravellir, for district heating in the countryside, and for fish-farming at Laxamýri. Water from the hot springs that is not utilized in this manner is led to Húsavík, where it is used for fish-farming and afterwards discarded into the Atlantic Ocean.

The water from geothermal wells H1, H10 and H16 is led into a gas separator at Hveravellir. The flow is controlled in such a way that the hottest well, H1, has a priority, then H10 and finally H16 is used upon demand, see article 4.1.

The gas emitted from the gas separator is mostly nitrogen, N<sub>2</sub>, in addition to small amounts of H<sub>2</sub>S.

After leaving the gas separator the geothermal water enters a 16 km long pipe leading to the Energy Center located just south of Húsavík. During periods of maximum flow in 2001 the water temperature dropped by 3°C on the way, arriving at the Energy Center at 121°C. During periods of less flow, this cooling is increased somewhat but is partly counteracted by the water entering the pipe somewhat hotter at Hveravellir.

The flow of water into the Energy Center can be controlled within the following limits:

- From Hveravellir: 0 to 95 l/s of geothermal water at 121°C.
- From fresh water supplies: 0 to 200 l/s of fresh water at 4°C.

From Energy Center water can be delivered at temperatures ranging between 4°C - 121°C, for:

- Electricity production.
- Industrial use.
- District heating.
- Fish-farming.
- Bathing lagoon.

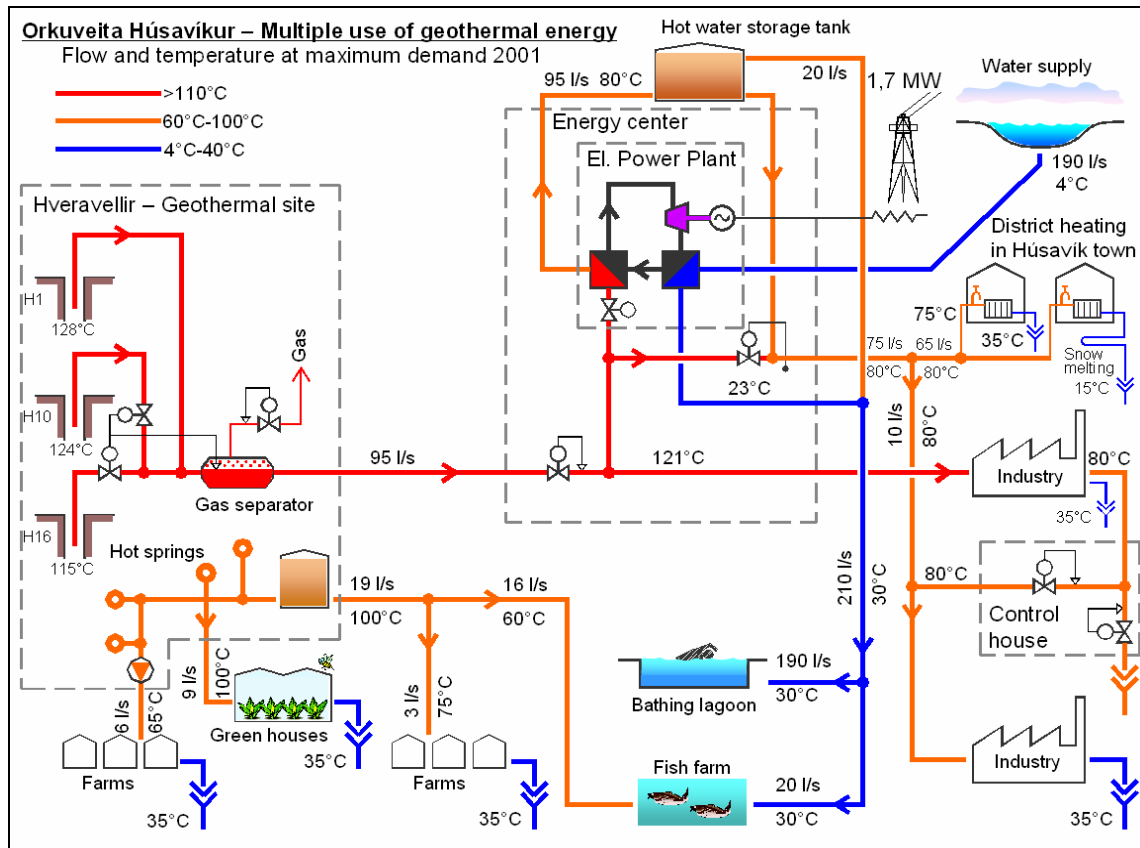

Fig. 3.2.1. Húsavík Energy – Multiple use of geothermal energy – Process diagram

Currently, all 121°C hot water is used to produce electricity. Should the market for industrial utilization of the water become more feasible, the production of electricity can be reduced and the water supplied to industry. The general policy of Húsavík Energy is however to continue full electricity production and drill additional wells if industrial demand increases.

The geothermal water is cooled from 121°C to 80°C in a heat exchanger after entering the Power Plant (see article 3.3). From there the 80°C water enters a storage tank from which it flows, via the district heating supply main, through the Power Plant before entering the distribution network of Húsavík. The 80°C water in Húsavík is used for various purposes, namely for district heating, fish drying, fish farming, etc.

### 3.3 Power Plant

The role of the Power Plant in the system is twofold: to produce electricity and to cool the geothermal water to a temperature suitable to the district heating system.

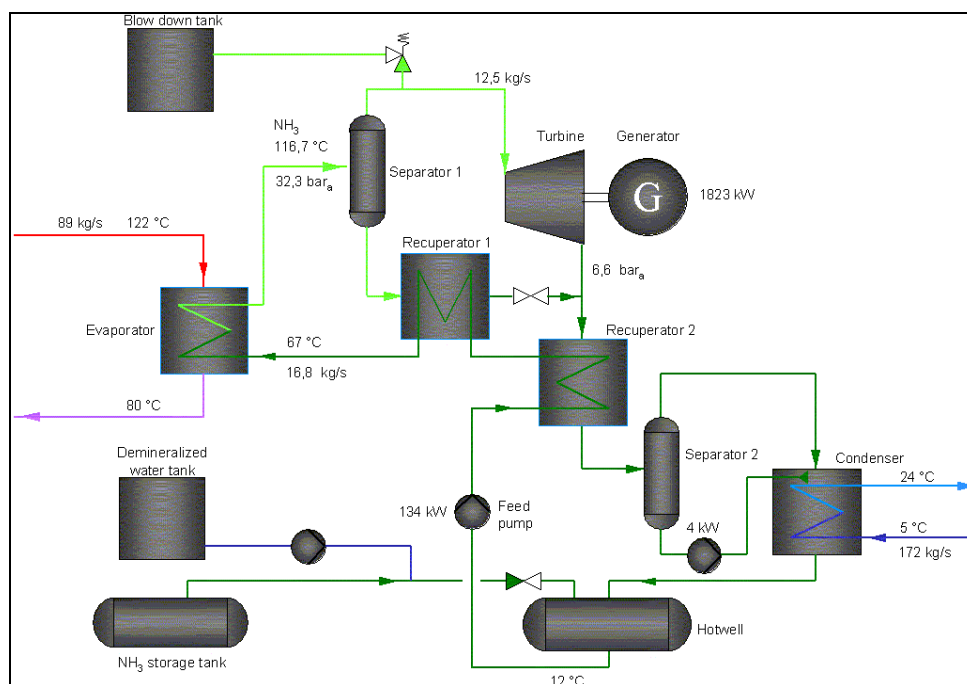

Fig 3.3.1 Power Plant – Schematic diagram

The Power Plant operates under the so called Kalina-technique, which is based on a closed cycle in which a water and ammonia mixture ( $\text{NH}_3\text{-H}_2\text{O}$ ) serve as the transfer medium (refrigerant). Unlike pure substances, which remain at a constant temperature during boiling or condensation, the mixture's temperature changes during these phase changes.

Once the transfer medium has been heated using geothermal water, it enters a separator, where liquid is separated from vapour. The vapour, rich with ammonia ( $\text{NH}_3$ ), is then led through a turbine where it expands when pressure is decreased. The energy created during this process is turned into electricity in a generator connected to the turbine. The liquid separated from the gas in the separator, is used to preheat the returning mixture in recuperator 1. Following this the liquid is reunited with the vapour and is cooled down in recuperator 2. Before entering the condenser a second separator is installed separating the phases and the water is pumped through inlet nozzles into the condenser where the ammonia vapour is condensed.

The cooling water exits the condenser into an effluent pipeline that leads to a man-made bathing lagoon, located south of the Power Plant. On its way there, part of the cooling water is withdrawn from the pipeline and used in fish-farming.

A schematic diagram of the production cycle is shown in **figure 3.3.1**. Initial design assumptions have been modified to reflect the actual geothermal characteristics encountered. All numbers in the diagram represent theoretical values based on the present conditions. The calculated output under the given conditions is some 7% less than theoretical calculations indicate. With proper selection of equipment the output can be calculated as high as 2,150 kW net as a recent offer from an expander manufacturer proves. During the final acceptance testing in November 2001 this output could not be reached but the acceptance certificate was issued as a result of an agreement with the contractor.

The Kalina-technique is recently developed and has never been applied to geothermal heat prior to the installation at Húsavík. Binary fluid systems are not new but the difference between the Kalina system and traditional versions lies in the type of transfer medium used in the closed electricity production cycle. As mentioned, the transfer medium in the Kalina cycle is a mixture of water and ammonia, while traditional ORC cycles use pentane. **Figure 3.3.2** shows the difference between these two fluids while boiling, namely that pentane boils at a constant temperature while temperature varies in a boiling water-ammonia mixture. This property of the transfer medium makes the efficiency of the Kalina cycle much better than that of a typical ORC cycle, given the conditions present at Húsavík.

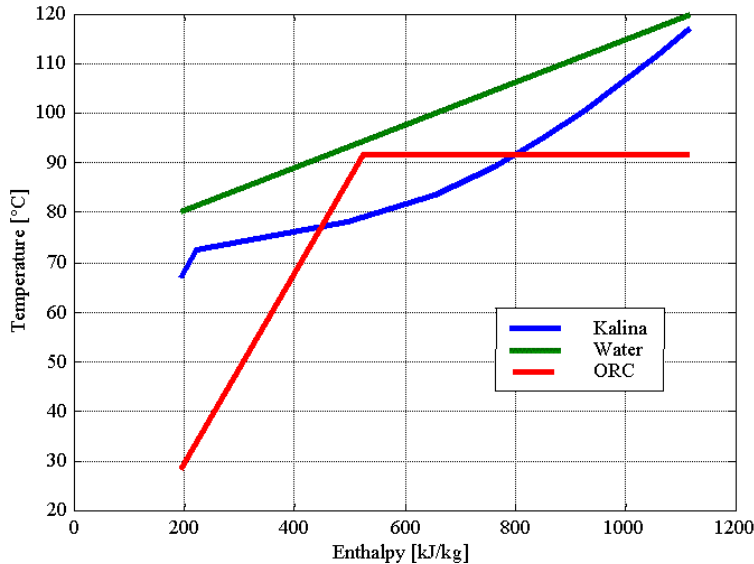

Fig 3.3.2. Comparison between boiling of the ammonia-mixture, pentane (ORC) and pure water.

## 4 Utilization of thermal power

As stated previously, much emphasis was assigned to obtaining flexibility within the Energy Center’s operational system, thereby enabling the most feasible/economical usage of the thermal energy at all times. Currently the pillars of the operation are the district heating services it provides and the electricity production. These two operational functions provide the Húsavík Energy with most of its revenue. The industrial use of 80°C water is also important to the operation, having the potential to expand should market conditions change favorably.

At present there is no 120°C water available for industrial utilization when electricity production is running at full capacity. However nothing prevents the delivery of 120°C water to industry outside high load periods of electricity production. When the demand for 120°C for industrial use becomes sufficient, additional wells will be drilled at Hveravellir. All piping and equipment needed for the transportation of this water to industrial consumers is already in place.

Heat energy for district heating, electricity production and industry is defined as priority energy. When the load ratio of these three factors is at its optimum, all hot water withdrawn can be utilized down to a temperature of 35°C, and at periods of lower loads down to 20°C. Large amounts of 20-35°C hot water resulting from the production remain unused so potential users of water at these temperatures can purchase the 20-35°C water at very economical prices. Snow melting and fish farming are two examples of ideal processes that utilize water at these temperatures. Presently this unsold water is led to a bathing lagoon constructed south of the Energy Center. Although this utilization of the water does not provide Húsavík Energy with any additional revenue, the bathing lagoon has acted towards improving the community at Húsavík in addition to having a positive future influence on tourism in the region.

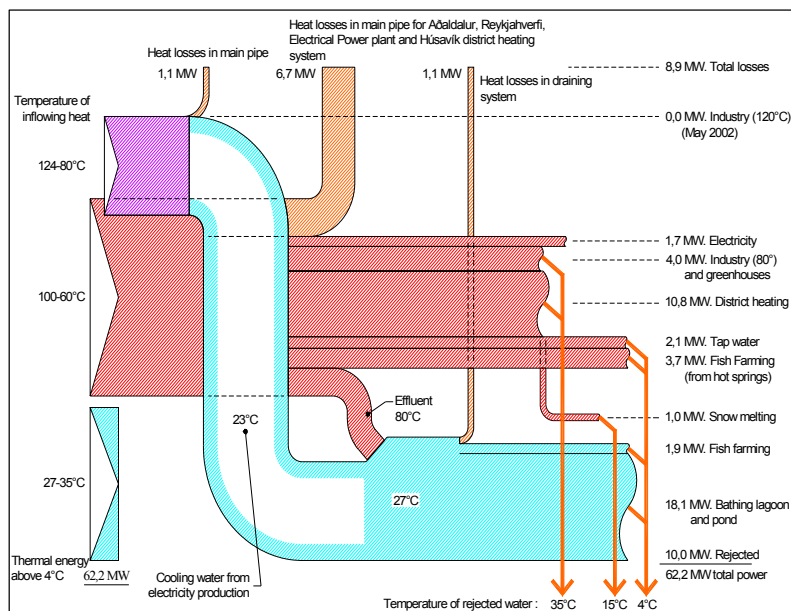

Table 4.1. and figure 4.1 provide an overview of the utilization of thermal power from the geothermal field from Hveravellir. The overview assumes utilization of thermal power above the temperature of the cold water supply at Húsavík or 4°C. The summary reflects utilization at maximum load on district heating and electricity production in the year 2001, see fig. 3.2.1.

Fig 4.1 A flow chart depicting the utilization of thermal energy above 4°C at maximum load

**Table 4.1 Utilization of thermal power above 4°C**

<b>Total power from geothermal field</b>	<b>62.2 MW</b>	<b>100%</b>
Power from wells H1, H10 and H16	48.5 MW	78%
Power from hot springs	13.7 MW	22%
<b>Sold power</b>	<b>25.2 MW</b>	<b>41%</b>
Space heating (75°- 35°C)	10.8 MW	17%
Tap water (bathing, washing) (75°- 4°C)	2.1 MW	3%
Electricity (121° - 80°C)	1.7 MW	3%
Industry, 120°C (121° - 80°C)	0 MW	0%
Industry, 80°C (75°- 35°C)	1.6 MW	3%
Greenhouses (100° - 35°C)	2.4 MW	4%
Snow melting (35°- 15°C)	1.0 MW	2%
Fish-farming (27° and 60°- 4°C)	5.6 MW	9%
<b>Surplus power utilized</b>	<b>18.1 MW</b>	<b>29%</b>
Bathing lagoon (27°- 4°C)	18.1 MW	29%
<b>Losses</b>	<b>8.9 MW</b>	<b>14%</b>
In pipeline from Hveravellir (124°- 121°C)	1.1 MW	2%
In Aðaldalur (100°- 75°C)	0.8 MW	1%
In Reykjahverfi (100°- 75°C)	1.3 MW	2%
In the old asbestos pipeline (100°- 60°C)	2.6 MW	4%
In Húsavík distribution system(80°- 75°C)	1.5 MW	2%
In effluent pipeline	1.1 MW	2%
In Power Plant	0.5 MW	1%
<b>Discarded power</b>	<b>10.0 MW</b>	<b>16%</b>
35°C hot water from space heating and industry	9.5 MW	15%
15°C hot water from snow melting	0.5 MW	1%

The annual utilization of thermal power differs considerably from power utilization at maximum load. The utilization period of maximum power for the electricity production is estimated at around 7,000 hours/year. The utilization period of maximum power for district heating is estimated as 4,400 hours/year and to industry around 6,000 hours/year. One of the results of this discrepancy between the various utilization periods is that outside periods of maximum load for district heating, more 80°C water than required by demand is produced at the Energy Center.

While market conditions for this surplus of 80°C water remain unchanged, the water will continue flowing to the bathing lagoon. Losses in main pipelines and in the distribution systems are quite uniform throughout the year, resulting in a higher percentile of the annual energy production than power at maximum load. Water from hot springs flows freely into collection pipes and during periods of low load, when demand does not require its utilization, this water flows unused into nearby streams and from there into the ocean. **Table 4.2.** summarizes the estimated annual utilization of thermal energy (above 4°C) withdrawn from the geothermal field.

**Table 4.2 Annual utilization of thermal energy above 4°C.**

<b>Total energy from the geothermal field</b>	<b>459 GWh</b>	<b>100%</b>
Energy from wells H1, H10 and H16	339 GWh	74%
Energy from hot springs	120 GWh	26%
<b>Sold energy</b>	<b>135 GWh</b>	<b>29%</b>
Space heating	48 GWh	10%
Tap water (baths, washes)	9 GWh	2%
Electricity	12 GWh	3%
Industry, 120°C	0 GWh	0%
Industry, 80°C	10 GWh	2%
Greenhouses	10 GWh	2%
Snow melting	1 GWh	0%
Fish farming	45 GWh	10%
<b>Surplus energy utilized</b>	<b>177 GWh</b>	<b>39%</b>
Bathing lagoon	177 GWh	39%
<b>Losses</b>	<b>75 GWh</b>	<b>17%</b>
In main pipelines and distribution systems.	75 GWh	17%
<b>Discarded energy</b>	<b>68 GWh</b>	<b>15%</b>
Water discarded from district heating	43 GWh	9%
Unused water from hot springs	25 GWh	6%



## 5 Conclusions

This report describes the utilization of geothermal energy at Húsavík Energy following changes to the district heating system performed in 1999-2000.

Since the construction of the new system was completed in the year 2001 the system as a whole has been operated without any problems, except for the Kalina power plant.

From the initial start up many problems were encountered regarding the Kalina power plant. Immediately at startup separator 1 caused problems, its performance being very poor and a far cry from its capacity. Big droplets of water seeped in with the ammonia gas entering the turbine, wearing it down unnecessarily and as well considerably limiting the plant's output. The separator was replaced after all attempts to rectify these problems proved fruitless.

Reducing the pressure in the condenser to its design value has also proven problematic despite there being more cooling water available than originally predicted. The condenser installed is not of a traditional type. It is a plate-heat exchanger for double phase flow, where the ammonia gas enters in the usual fashion, but the liquid is sprayed in through special nozzles. The placement of these nozzles has been varied with positive results, but despite this the performance of the condenser is less than 100%. Additional heating surface (plates) will improve the situation.

The acceptance certificate was issued after the November 2001 testing. The output was less than calculations indicated, however the certificate was issued as a result of an agreement with the contractor.

The power plant was operated at that demand for approximately six months without any problem. At routine inspection in May 2002, damage due to wear was again noticed. First it was believed that separator 1 was still not functioning properly. Further inspection proved the damage was caused by corrosion of the turbine interior. The blades are made of 13%Cr steel. Now it has been decided to replace the turbine interior with titanium.

As part of the ongoing betterment of the plant an offer of an expander giving some 2,150 kW net under the given conditions show that the power plant cycle can still be improved considerably.

After the turbine repair it is reason to believe that the Power Plant will be an outstanding example of an efficient operation and efficient multi use of geothermal energy.

The main difference between the old system and the new one lies in the utilization of the power contained in steam that prior to the changes was released into the atmosphere. This power is now used to produce electricity. In addition Húsavík Energy can now offer 120°C hot water for sale to industry and the possibility of selling water at temperatures between 80°C and 40°C has improved greatly.

Flexible utilization of the heat was emphasized, enabling the system to utilize the energy as efficiently as possible under varying conditions at each time. This flexibility provides Húsavík Energy with the opportunity of purchasing electricity from elsewhere and selling the 121°C hot water otherwise used for electricity production to industry, should such utilization provide the company with more revenue. Hot surplus water now flows to a bathing lagoon, which can be enjoyed by inhabitants and visitors to Húsavík, free of charge. Despite the lagoon not providing Húsavík Energy with any direct revenue, it contributes to a more pleasant environment for everyone.

It is the opinion of the report's authors that the objectives set forth for the multiple energy system project in Húsavík have been obtained.

## 6 References

- [1] Fjarhitun hf., December 1996 -Endurnýjun hitaveitu–langtímaáætlun.
- [2] VGK, October 1997 - Húsavík Energy – Frumáætlun raforkuvinnslu,
- [3] Fjarhitun hf, 009/Mars 1997 - Hitaveita Húsavíkur – Mælingar á heitu vatni á Hveravöllum,
- [4] Orkustofnunar/Gax 20/01/98 - The Hveravellir Geothermal Field, NE-Iceland, Conceptual Model and Reservoir Assessment,.
- [5] Fjarhitun hf., May 1998 - Nýtt hitaveitukerfi. Frumhönnun 1. áfangi–kerfishönnun.
- [6] Húsavík Energy, January 1998 - Innovative Use of Low Temperature Geothermal Energy in Industry, Heating and Electricity Production (GEOHEATINDEL). Thermie Application to the European Union,
- [7] Fjarhitun hf., Sept. 1998 – Orkuveita Húsavíkur – Nýtt hitaveitukerfi og rafstöð – Arðsemismat,.
- [8] Fjarhitun hf., VGK, December 1998 – Orkuveita Húsavíkur – Nýtt hitaveitukerfi og rafstöð, frumhönnun.
- [9] Húsavík Energy - Annual reports 1993-1997.